



ThermoLite™ Solar Panels

The most advanced solar charging solution for every need under the sun.





*REDUCE COSTLY DOWNTIME AND
SUPPORT SUSTAINABILITY PLANS WITH A
SOLAR CHARGING SYSTEM.*

ThermoLite™ solar panels can deliver clean, reliable performance in a wide variety of applications, resulting in longer battery life, decreased waste, lower fuel consumption and reduced emissions. Given these potential benefits, ThermoLite solar panels can be an important part of a comprehensive sustainability program for your business. New products like the ThermoLite solar panels are a key part of Ingersoll Rand's plan to significantly increase energy efficiency and reduce climate impact.

***THERMOLITE
BENEFITS INCLUDE:***

- Optimized to offset controller and telematics loads
- Greatly extends battery life and prevents costly road calls
- High efficiency solar cells use latest technology to produce abundant power, even in low light conditions
- Designed for quick, easy installation in all applications
- Weatherproof panel construction for extreme durability and long system life
 - 20+ year anticipated product life
 - 4 year full product warranty (see dealer for details)



CUSTOMER ROI

SOLAR CHARGING BRINGS VALUE IN SEVERAL KEY AREAS:

1. Unit battery life - 40-200% improvement
2. Asset downtime improvement
3. Fuel savings
 - Cycle Sentry charging
 - Alternator and engine offloading

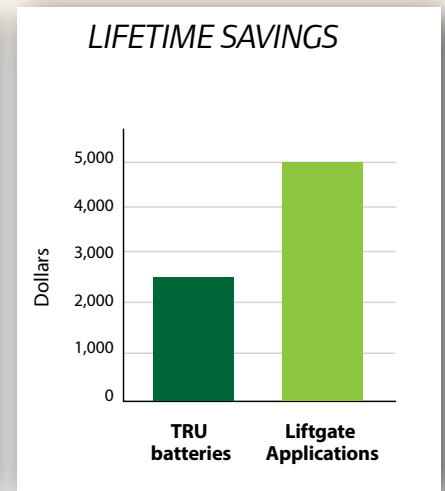
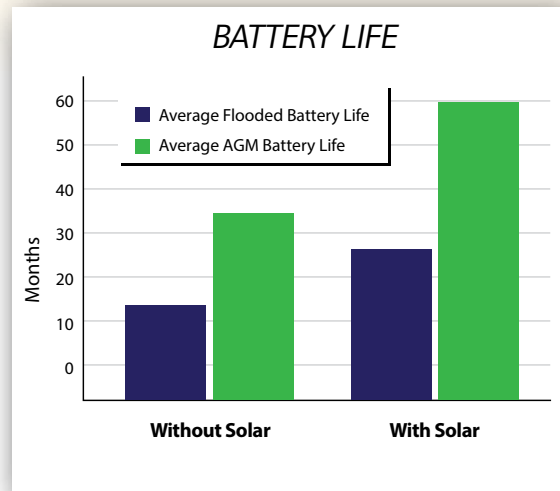

ThermoLite CHARGE CONTROLLER



THE BRAINS OF THE SYSTEM:

- Critical to proper battery charging and system reliability
- Smart, three-stage charging technology via DC-DC converter
- Completely sealed against the environment
- Rugged automotive-rated circuit design
- Regulates both voltage and current to keep batteries from overcharging
- Designed to support AGM and flooded batteries

A FULL RANGE OF SOLAR SOLUTIONS FOR

26W PANEL



- ✓ Effectively offsets telematics
- ✓ Supports Thermo King and competitive reefer batteries
- ✓ Protects battery charge during extended unit-off situations

SPECIFICATIONS

Peak Output Power:	26W
Nominal Voltage:	12v
Weight:	6 lbs.
Panel Size:	13" x 22"
Warranty:	4 Years
Base Kit Part Number:	401269
SB Adapter Bracket:	401271
SB Intermodal Adapter Bracket:	401272
Competitive Adapter Kit	903364

36W PANEL



- ✓ Supports Heat King units and competitive reefer batteries
- ✓ Supports tractor telematics
- ✓ Flexible panel designed to fit competitive units

SPECIFICATIONS

Peak Output Power:	36W
Nominal Voltage:	12v
Weight:	6 lbs.
Panel Size:	13" x 22"
Warranty:	4 Years
Base Kit Part Number:	401270
DRC Harness:	401273

ALL APPLICATIONS

PANEL



domestic rail containers

curved surfaces

36W
12v
2 lbs.
13" x 29"
4 Years
401270
401293

100-300W PANEL

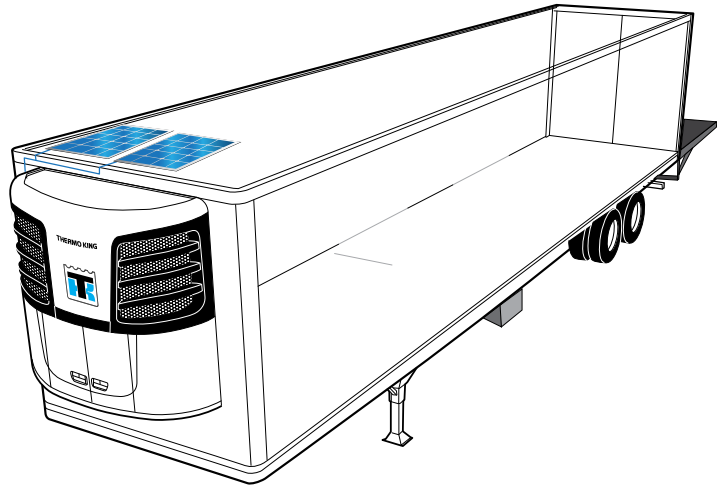

- ✓ Supports lift gates, pallet jacks and other large loads
- ✓ Max 300W combined into one system
- ✓ Suitable for all truck and trailer applications

SPECIFICATIONS

Peak Output Power:	100W
Nominal Voltage:	12v
Weight:	5 lbs.
Panel Size:	22" x 45"
Warranty:	4 Years
Base Kit Part Number:	401300
100W Expansion Kit:	401301
8' Installation Harness:	422405
25' Installation Harness:	422406
50' Installation Harness:	422407



ThermoLite COMPETITIVE ADVANTAGE

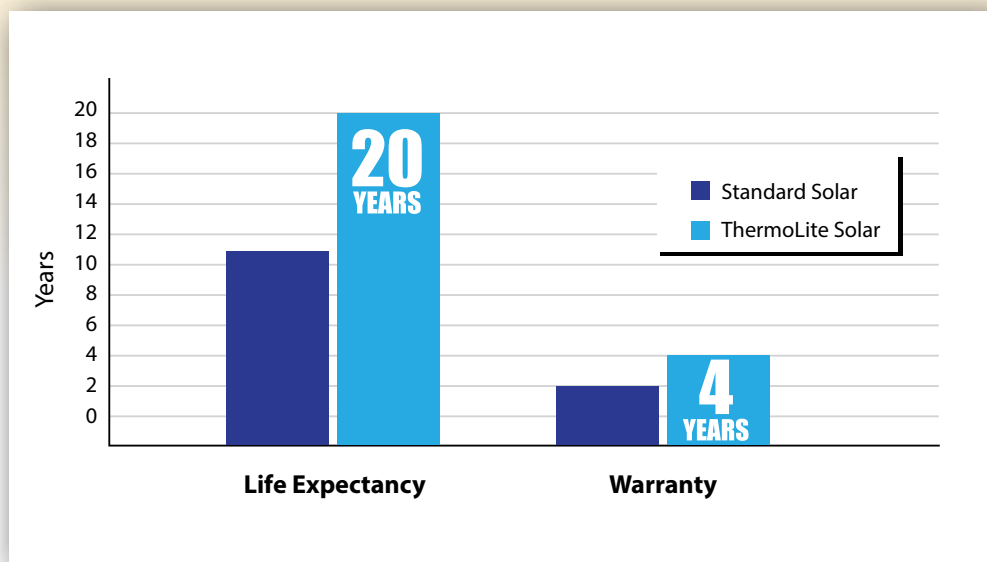

ThermoLite:

- Custom-engineered solution
- Only automotive-rated charge controller on the market
- 20+ year product life - designed to last beyond life of the unit
- Designed to fit Thermo King and competitive units
- High-efficiency PV cells to drive maximum power density in a small space
- Panel constructed of flexible polymer that allows bending and high environmental resistance

Competition:

- Reefer charging panels generally not large enough (need at least 25W)
- Won't mount directly to the unit
 - Dramatically increases install time and complexity
 - Systems are not designed to be short, adding significant height
- NOT rated for automotive environments
 - Charge controller not designed for automotive batteries
 - Glass construction is fragile
 - Uses residential solar connectors (proven to be not rated for automotive environment)

SOLAR PANEL COMPARISON GUIDE



	ThermoLite			Competitor's Panel	Generic Panel
	26W	36W	100W		
Size	13" x 22"	13" x 29"	22" x 45"	40.5" x 26.5"	14" x 30"
Weight	6 lbs	2 lbs	5 lbs	4 lbs	10 lbs
Output	26W peak output	36W peak output	100W peak output	28W peak output	30W peak output
Install time	30 minutes	60 minutes	90 minutes	90 minutes	At least 60 minutes
Panel Construction	Flexible polymer	Flexible polymer	Flexible polymer	Amorphous silicon	Polycrystalline (Glass)
Warranty	4 years - Full warranty	4 years - Full warranty	4 years - Full warranty	5 years - Limited warranty	1 year - Limited warranty
Install Conditions	Any	40°F-100°F	40°F-100°F	Must be in shade, dry, and between 40°F-80°F	Any
3-Stage Charge Controlling	✓	✓	✓		
High-Flex, Low Temp Automotive Wiring	✓	✓	✓		
Plug & Play Connectivity	✓	✓	✓	✓	
Produces Power In low light	✓	✓	✓	✓	
Automotive Rated	✓	✓	✓		
Unit Mountable	✓	✓			



EXPERT SERVICE AND SUPPORT ARE AS CLOSE AS THIS SIGN.

SUPPORTED BY A NETWORK OF FACTORY-AUTHORIZED SERVICE CENTERS NATIONWIDE!

Choose ThermoLite Solar Panels and enjoy the support of the Thermo King Dealer Network.



Ingersoll Rand (NYSE:IR) advances the quality of life by creating comfortable, sustainable and efficient environments. Our people and our family of brands—including Club Car®, Ingersoll Rand®, Thermo King® and Trane®—work together to enhance the quality and comfort of air in homes and buildings; transport and protect food and perishables; and increase industrial productivity and efficiency. We are a \$13 billion global business committed to a world of sustainable progress and enduring results.



ingersollrand.com

